

2023 COLLECTION | SHOTGUN | PCP AIR RIFLE



ASELKON

www.aselkonarms.com

www.aselkonarms.com



We, ASELKON AŞ, are a well established international company that manufactures and exports Hunting, Sporting, and Tactical Military Purpose Shotguns, Pistols, PCP Air Rifles and all spare parts of firearms in accordance with internationally accepted standards, especially to ATF and CIP proof tests, and Country-Specific Firearms Compliance Regulations. We've been actively operating in the firearms sector since 2006 with our vast experience in manufacturing and exporting to more than 50 countries. Our products are highly appreciated in many leading markets in the world.

Thanks to our 40.000 m² fully integrated production facility, with our dynamic, productive and experienced technical staff, we manufacture every parts of guns from raw material to final product in our own facilities without depending on any

external factor. In this way, in every stage of production we manage our quality control perfectly and provide a high level of quality assurance.

As well as our major operations in international markets, we continue to cooperate with government and military forces in delivering diverse projects regarding armored vehicles, missile launcher platforms, crane – machinery and construction industry.

As being one of the leading manufacturers in firearms industry, we constantly improve our product and service quality with the concepts of high automation and flexibility in order to provide better quality products and effective solutions for the needs customers. We always aim the best in quality and increase the customer satisfaction.

FUNCTIONING | STOCK DETAILS



- ① FUNCTIONING TEST
- ② CONDITIONS TEST
- ③ 3D & GUN CHECKS TEST
- ④ ACCURACY TEST
- ⑤ PRESSURE DROP TEST



DAC is can be adjustable to 35-39 mm



DAH is can be adjustable to 45-50-55-60 mm

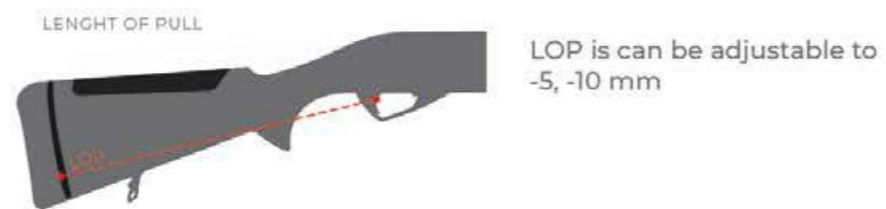

LOP is can be adjustable to -5, -10 mm



SHOTGUN

| | | | | | | | |
|-----------|-------|-----------------|-------|---------------------|-------|---------------|---------|
| X3 | 10-21 | inter | 46-59 | Super MAGNUM | 76-87 | STATO4 | 100-109 |
| X4 | 22-33 | RedStone | 60-71 | OVER/UNDER | 88-94 | STATO3 | 110-119 |
| X5 | 34-45 | RedSport | 72-75 | TACTICAL | 94-99 | ASK12 | 120-123 |

PCP AIR RIFLES

| | | | | | | | |
|----------------------|---------|--------------|---------|---------------|---------|---------------|---------|
| EMPERADOR LS1 | 128-129 | MX5 | 136-137 | MX8 | 144-145 | RX5 | 152-153 |
| EMPERADOR LS2 | 130-131 | MX6 | 138-139 | MX9 | 146-147 | RX6 | 154-155 |
| EMPERADOR LS3 | 132-133 | MX7 | 140-141 | MX10 | 148-149 | RX1250 | 156-157 |
| EMPERADOR LS4 | 134-135 | MX7-S | 142-143 | MX10-S | 150-151 | | |



Shotguns

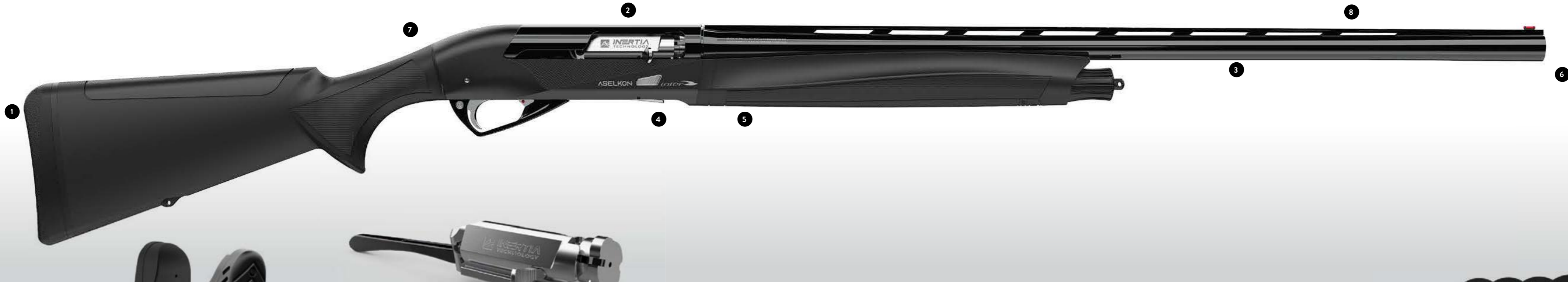

SWIVEL KIT



Aselkon recoil pads which are made of a mixture of special polyurethane and rubber materials minimize the recoil and provides a comfortable targeting and shooting.

1

INERTIA TECHNOLOGY

Our proprietary refinements to the ultra-reliable Bruno Civolani "floating bolt" action ensure the Aselkon Shotguns are able to quickly cycle even the lightest 12 gauge loads. Inertia system consists of 3 main parts; bolt mechanism, rotating bolt, and inertia spring. Thanks to its simple combination, inertia system functions faster and flawlessly. Unlike the gas operated systems, since the burnt powder gas does not contact with the mechanism, system remains clean and requires less maintenance. Aselkon's rotating bolt utilizes our unstoppable Inertia Technology Locking System to ensure positive bolt head lock-up to the breach under all conditions.



2



Each Aselkon barrel is subjected to a proof test with 1500 BAR high pressure test cartridge before leaving our factory.

3



Aselkon's improved loading mechanism provides the user quite a smooth loading.

4



The center of gravity is balanced on the forend to ensure a comfortable carry and practical shooting.

5

COMPARISON OF MUZZLE CLIMBING

| | |
|------------|------|
| BRAND A | 85 % |
| BRAND A | 75 % |
| BRAND A | 60 % |
| INTER ARMS | 50 % |



INTERPROCHOKE

We engineered the interchangeable InterPro Chokes to maximize the constancy of shot placement through reduced friction that enhances load speeds.

6



DROP & CAST ADJUSTMENT

7

INTERBORED BARREL

Aselkon barrels are standard with our precision drilling, honing and chrome coating process. Aselkon Barrels are designed to increase accuracy, to shoot comfortably and function superbly with both light and heavy loads.

8





X3

the most
COMFORT POWER

INERTIA
TECHNOLOGY

1500
BAR

EASY
LOAD

INTER.
BALANCED

INTERPROCHOKE

INTERBORED BARREL

COMFORT
RECOIL

LUXURY
WOOD



X3 DARK BLACK



X3 BRONZE PURE



X3 SILVER



X3 SILVER LIGHT



X3 MATTE BLACK



X3 GRAY LIGHT



X3 EXTRA BLACK



X3 BOTTOMLAND BRONZE



X3 BOTTOMLAND



X3 CAMO MAX5



X3 ELEGANT SILVER BLACK



X3 ELEGANT BLACK



X3 ELEGANT SILVER



X3 ELEGANT BRONZE



X3 ELEGANT SEA GREEN



X4

the most
COMFORT POWER



INERTIA TECHNOLOGY **1500 BAR** **EASY LOAD** **INTER. BALANCED** **INTERPROCHOKE** **INTERBORED BARREL** **COMFORT RECOIL** **LUXURY WOOD**



X4 SILVER



X4 DARK BLACK



X4 BRONZE PURE



X4 SILVER LIGHT



X4 MATTE BLACK



X4 EXTRA BLACK



X4 GRAY LIGHT



X4 BRONZE LIGHT



X4 BOTTOMLAND BRONZE



X4 BOTTOMLAND



X4 CAMO MAX5



X4 ELEGANT SILVER BLACK



X4 ELEGANT BLACK



X4 ELEGANT SILVER



X4 ELEGANT BRONZE



X4 ELEGANT SEA GREEN



X5

the most
COMFORT POWER

INERTIA
TECHNOLOGY

1500
BAR

EASY
LOAD

INTER.
BALANCED

INTERPLUSCHOKE

INTERBOREDBARREL

COMFORT
RECOIL

LUXURY
WOOD



X5 SILVER



X5 DARK BLACK



X5 BRONZE PURE



X5 SILVER LIGHT



X5 MATTE BLACK



X5 EXTRA BLACK



X5 GRAY LIGHT



X5 BRONZE LIGHT



X5 BOTTOMLAND BRONZE



X5 BOTTOMLAND



X5 CAMO MAX5



X5 ELEGANT SILVER BLACK



X5 ELEGANT BLACK



X5 ELEGANT SILVER



X5 ELEGANT BRONZE



X5 ELEGANT SEA GREEN



inter

the most
COMFORT POWER

INERTIA
TECHNOLOGY

1500
BAR

EASY
LOAD

INTER.
BALANCED

INTERPROCHOKE

INTERBOREDBARREL

COMFORT
RECOIL

LUXURY
WOOD



INTER DARK BLACK



INTER BRONZE PURE



INTER SILVER





INTER EXTRA BLACK



INTER GRAY LIGHT



INTER MATTE BLACK



INTER BRONZE LIGHT



INTER SILVER LIGHT

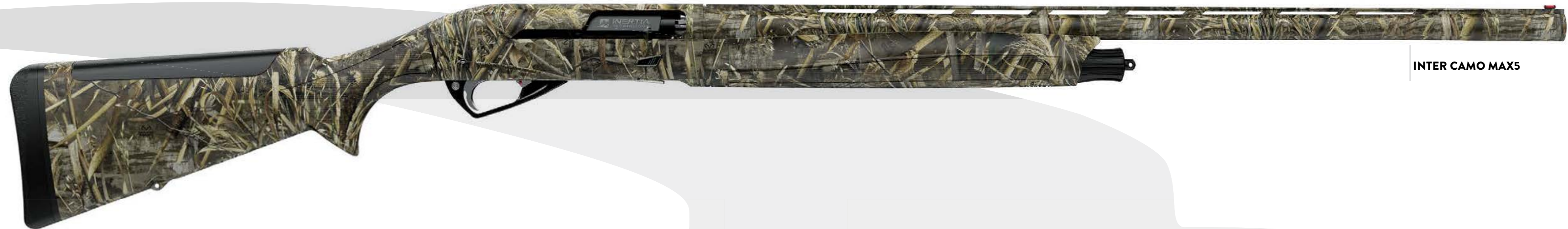

INTER CAMO MAX5



**INTER BOTTOMLAND
BRONZE**



**INTER TIMBER
BRONZE**



INTER BOTTOMLAND



INTER TIMBER



elegant

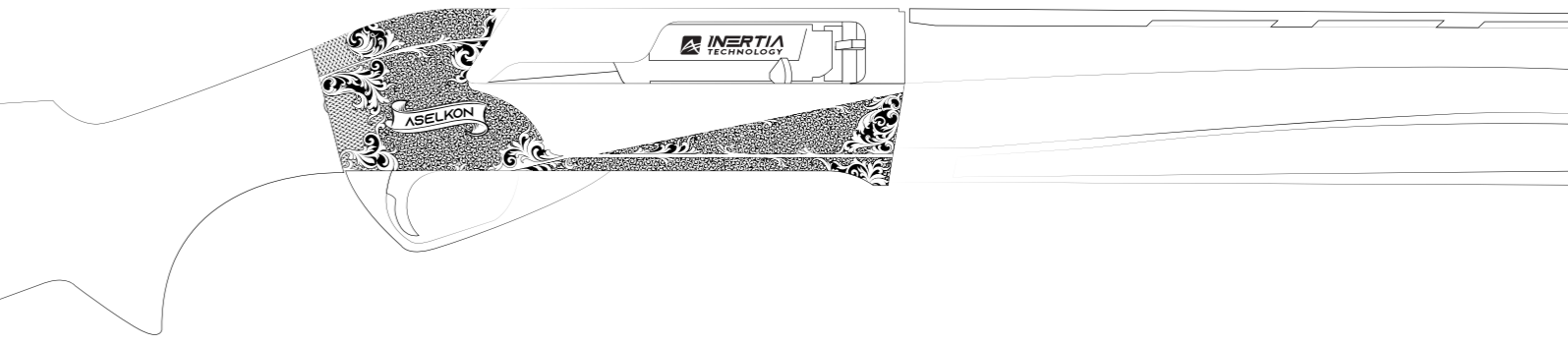

inter 



INTER ELEGANT SILVER BLACK



INTER ELEGANT BLACK



INTER ELEGANT SILVER



INTER ELEGANT BRONZE



INTER ELEGANT SEA GREEN



RedStone 

the most
COMFORT POWER

INERTIA
TECHNOLOGY

1500
BAR



INTER.
BALANCED

INTERPLUSCHOKE

INTERBOREDBARREL

COMFORT
RECOIL

LUXURY
WOOD



REDSTONE DARK BLACK



REDSTONE BRONZE PURE



REDSTONE SILVER



REDSTONE SILVER LIGHT



REDSTONE BRONZE LIGHT



REDSTONE MATTE BLACK



REDSTONE EXTRA BLACK



REDSTONE GRAY LIGHT





REDSTONE BOTTOMLAND



**REDSTONE
BOTTOMLAND BRONZE**



**REDSTONE
TIMBER BRONZE**



REDSTONE CAMO MAX5





REDSTONE ELEGANT SILVER BLACK



REDSTONE ELEGANT BLACK

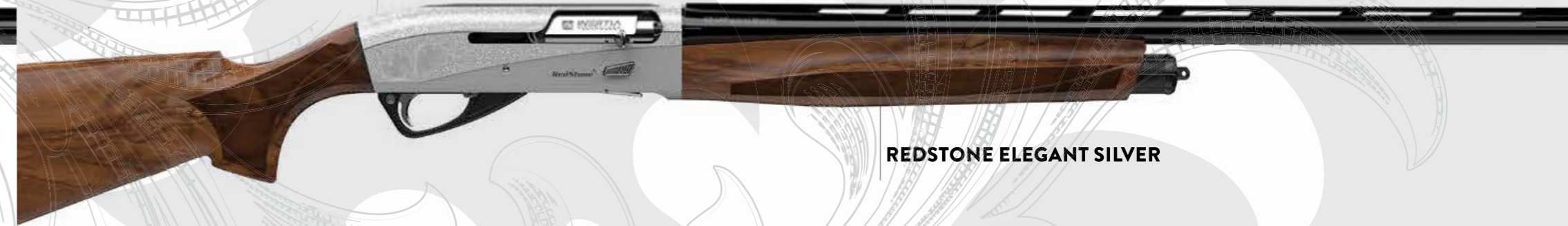

REDSTONE ELEGANT SILVER

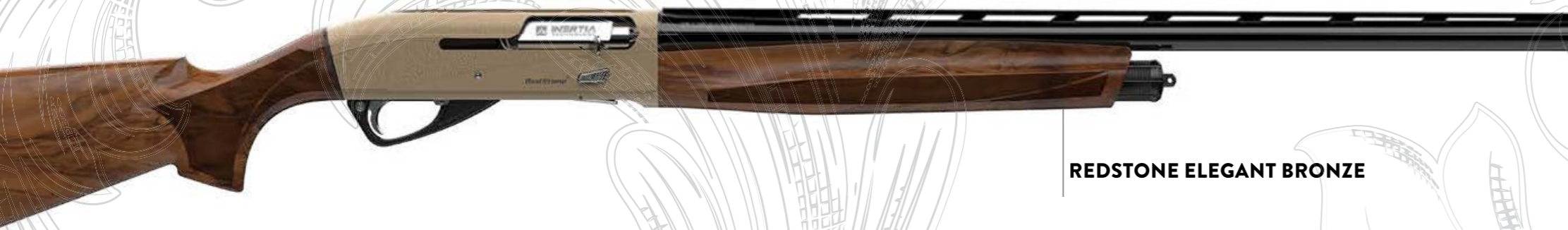

REDSTONE ELEGANT BRONZE

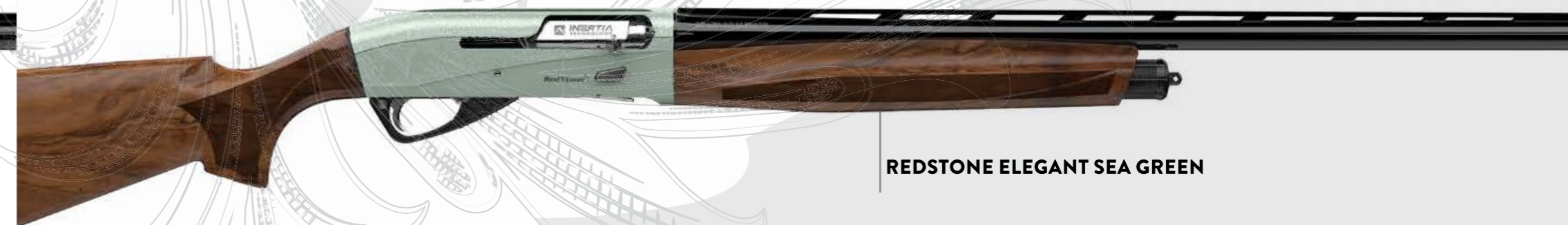

REDSTONE ELEGANT SEA GREEN



RedSport

the most
COMFORT POWER

INERTIA
TECHNOLOGY

1500
BAR

EASY
LOAD

INTER.
BALANCED

INTERPLUSCHOKE

INTERBOREDBARREL

COMFORT
RECOIL

LUXURY
WOOD



Gauge

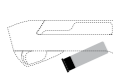

Chamber

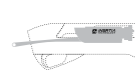

Action

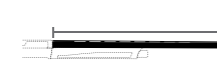

Barrel length



Barrel



Choke



Rib



Stock length



Drop at heel

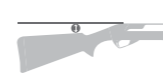

Drop at comb



Weight



Forend

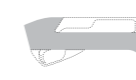

Receiver

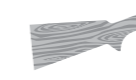

Stock



Magazine Capacity



Safety



Trigger Guard



Trigger



Sight



Recoil Pad

Red Sport

12 GA 3"

76 mm

Kinetic Drive Inertial System
Semiautomatic, Rotating Bolt

61-66-71-76 cm

Chrome-Lined, 4140 Steel
Inter Bored Barrel5 InterPro
C-IC-M-IM-F8 mm / High
Rib

340 mm

55±1 mm, 45-50-60 mm
Adjustable

37±1 mm

2.85± kg

Synthetic

Aluminium Anodized
Cerakote Coating

Synthetic

9+1/10+1

Trigger Safety

Special
PolyurethaneTrigger Safety, Automatic Locking
System, Anti-Repeat SystemFiber Optic
SightSpecial
Polyurethane Pad



Super
MAGNUM

the most
COMFORT POWER

INERTIA
TECHNOLOGY

1500
BAR

EASY
LOAD

.INTER.
BALANCED

INTERPROCHOKE

INTERBOREDBARREL

COMFORT
RECOIL

LUXURY
WOOD



**3,5" INTER
SUPER MAGNUM CAMO MAX5**



**3,5" INTER
SUPER MAGNUM TIMBER**



**3,5" INTER
SUPER MAGNUM TIMBER BRONZE**



**3,5" INTER
SUPER MAGNUM EXTRA BLACK**



**3,5" INTER
SUPER MAGNUM BOTTOMLAND BRONZE**



**3,5" INTER
SUPER MAGNUM BOTTOMLAND**



**3,5" REDSTONE
SUPER MAGNUM TIMBER**



**3,5" REDSTONE
SUPER MAGNUM CAMO MAX5**



**3,5" REDSTONE
SUPER MAGNUM TIMBER BRONZE**



**3,5" REDSTONE
SUPER MAGNUM EXTRA BLACK**



**3,5" REDSTONE
SUPER MAGNUM BOTTOMLAND BRONZE**



**3,5" REDSTONE
SUPER MAGNUM BOTTOMLAND**



Gauge

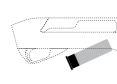

Chamber

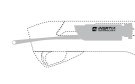

Action



Barrel length



Barrel



Choke



Rib

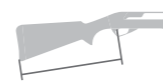

Stock length



Drop at heel

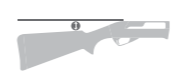

Drop at comb



Weight



Forend



Receiver

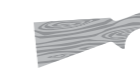

Stock



Magazine Capacity



Safety



Trigger Guard



Trigger



Sight



Recoil Pad

| | Gauge | Chamber | Action | Barrel length | Barrel | Choke | Rib | Stock length | Drop at heel | Drop at comb | Weight | Forend | Receiver | Stock | Magazine Capacity | Safety | Trigger Guard | Trigger | Sight | Recoil Pad |
|---|------------|---------|--|----------------|---|------------------------|-----------------|--------------|---------------------------------|--------------|----------|------------|---------------------------------------|------------|----------------------|----------------|----------------------|--|-------------------|--------------------------|
| Inter Super Magnum Extra Black | 12 GA 3.5" | 89 mm | Kinetic Drive Inertial System Semiautomatic, Rotating Bolt | 61-66-71-76 cm | Chrome-Lined, 4140 Steel Inter Bored Barrel | 5 InterPro C-IC-M-IM-F | 8 mm / High Rib | 340 mm | 55±1 mm, 45-50-60 mm Adjustable | 37±1 mm | 3.10± kg | Synthetic | Aluminium Anodized Cerakote Coating | Synthetic | 2+1x12/89 Extendable | Trigger Safety | Special Polyurethane | Trigger Safety, Automatic Locking System, Anti-Repeat System | Fiber Optic Sight | Special Polyurethane Pad |
| Inter Super Magnum Bottomland | 12 GA 3.5" | 89 mm | Kinetic Drive Inertial System Semiautomatic, Rotating Bolt | 61-66-71-76 cm | Chrome-Lined, 4140 Steel Inter Bored Barrel | 5 InterPro C-IC-M-IM-F | 8 mm / High Rib | 340 mm | 55±1 mm, 45-50-60 mm Adjustable | 37±1 mm | 3.10± kg | Bottomland | Aluminium Anodized Bottomland Coating | Bottomland | 2+1x12/89 Extendable | Trigger Safety | Special Polyurethane | Trigger Safety, Automatic Locking System, Anti-Repeat System | Fiber Optic Sight | Special Polyurethane Pad |
| Inter Super Magnum Bottomland Bronze | 12 GA 3.5" | 89 mm | Kinetic Drive Inertial System Semiautomatic, Rotating Bolt | 61-66-71-76 cm | Chrome-Lined, 4140 Steel Inter Bored Barrel | 5 InterPro C-IC-M-IM-F | 8 mm / High Rib | 340 mm | 55±1 mm, 45-50-60 mm Adjustable | 37±1 mm | 3.10± kg | Bottomland | Aluminium Anodized Cerakote Coating | Bottomland | 2+1x12/89 Extendable | Trigger Safety | Special Polyurethane | Trigger Safety, Automatic Locking System, Anti-Repeat System | Fiber Optic Sight | Special Polyurethane Pad |
| Inter Super Magnum Timber | 12 GA 3.5" | 89 mm | Kinetic Drive Inertial System Semiautomatic, Rotating Bolt | 61-66-71-76 cm | Chrome-Lined, 4140 Steel Inter Bored Barrel | 5 InterPro C-IC-M-IM-F | 8 mm / High Rib | 340 mm | 55±1 mm, 45-50-60 mm Adjustable | 37±1 mm | 3.10± kg | Timber | Aluminium Anodized Timber Coating | Timber | 2+1x12/89 Extendable | Trigger Safety | Special Polyurethane | Trigger Safety, Automatic Locking System, Anti-Repeat System | Fiber Optic Sight | Special Polyurethane Pad |
| Inter Super Magnum Timber Bronze | 12 GA 3.5" | 89 mm | Kinetic Drive Inertial System Semiautomatic, Rotating Bolt | 61-66-71-76 cm | Chrome-Lined, 4140 Steel Inter Bored Barrel | 5 InterPro C-IC-M-IM-F | 8 mm / High Rib | 340 mm | 55±1 mm, 45-50-60 mm Adjustable | 37±1 mm | 3.10± kg | Timber | Aluminium Anodized Cerakote Coating | Timber | 2+1x12/89 Extendable | Trigger Safety | Special Polyurethane | Trigger Safety, Automatic Locking System, Anti-Repeat System | Fiber Optic Sight | Special Polyurethane Pad |
| Inter Super Magnum Camo Max5 | 12 GA 3.5" | 89 mm | Kinetic Drive Inertial System Semiautomatic, Rotating Bolt | 61-66-71-76 cm | Chrome-Lined, 4140 Steel Inter Bored Barrel | 5 InterPro C-IC-M-IM-F | 8 mm / High Rib | 340 mm | 55±1 mm, 45-50-60 mm Adjustable | 37±1 mm | 3.10± kg | Camo Max5 | Aluminium Anodized Camo Max5 Coating | Camo Max5 | 2+1x12/89 Extendable | Trigger Safety | Special Polyurethane | Trigger Safety, Automatic Locking System, Anti-Repeat System | Fiber Optic Sight | Special Polyurethane Pad |
| Redstone Super Magnum Extra Black | 12 GA 3.5" | 89 mm | Kinetic Drive Inertial System Semiautomatic, Rotating Bolt | 61-66-71-76 cm | Chrome-Lined, 4140 Steel Inter Bored Barrel | 5 InterPro C-IC-M-IM-F | 8 mm / High Rib | 340 mm | 55±1 mm, 45-50-60 mm Adjustable | 37±1 mm | 3.10± kg | Synthetic | Aluminium Anodized Cerakote Coating | Synthetic | 2+1x12/89 Extendable | Trigger Safety | Special Polyurethane | Trigger Safety, Automatic Locking System, Anti-Repeat System | Fiber Optic Sight | Special Polyurethane Pad |
| Redstone Super Magnum Bottomland | 12 GA 3.5" | 89 mm | Kinetic Drive Inertial System Semiautomatic, Rotating Bolt | 61-66-71-76 cm | Chrome-Lined, 4140 Steel Inter Bored Barrel | 5 InterPro C-IC-M-IM-F | 8 mm / High Rib | 340 mm | 55±1 mm, 45-50-60 mm Adjustable | 37±1 mm | 3.10± kg | Bottomland | Aluminium Anodized Bottomland Coating | Bottomland | 2+1x12/89 Extendable | Trigger Safety | Special Polyurethane | Trigger Safety, Automatic Locking System, Anti-Repeat System | Fiber Optic Sight | Special Polyurethane Pad |
| Redstone Super Magnum Bottomland Bronze | 12 GA 3.5" | 89 mm | Kinetic Drive Inertial System Semiautomatic, Rotating Bolt | 61-66-71-76 cm | Chrome-Lined, 4140 Steel Inter Bored Barrel | 5 InterPro C-IC-M-IM-F | 8 mm / High Rib | 340 mm | 55±1 mm, 45-50-60 mm Adjustable | 37±1 mm | 3.10± kg | Bottomland | Aluminium Anodized Cerakote Coating | Bottomland | 2+1x12/89 Extendable | Trigger Safety | Special Polyurethane | Trigger Safety, Automatic Locking System, Anti-Repeat System | Fiber Optic Sight | Special Polyurethane Pad |
| Redstone Super Magnum Timber | 12 GA 3.5" | 89 mm | Kinetic Drive Inertial System Semiautomatic, Rotating Bolt | 61-66-71-76 cm | Chrome-Lined, 4140 Steel Inter Bored Barrel | 5 InterPro C-IC-M-IM-F | 8 mm / High Rib | 340 mm | 55±1 mm, 45-50-60 mm Adjustable | 37±1 mm | 3.10± kg | Timber | Aluminium Anodized Timber Coating | Timber | 2+1x12/89 Extendable | Trigger Safety | Special Polyurethane | Trigger Safety, Automatic Locking System, Anti-Repeat System | Fiber Optic Sight | Special Polyurethane Pad |
| Redstone Super Magnum Timber Bronze | 12 GA 3.5" | 89 mm | Kinetic Drive Inertial System Semiautomatic, Rotating Bolt | 61-66-71-76 cm | Chrome-Lined, 4140 Steel Inter Bored Barrel | 5 InterPro C-IC-M-IM-F | 8 mm / High Rib | 340 mm | 55±1 mm, 45-50-60 mm Adjustable | 37±1 mm | 3.10± kg | Timber | Aluminium Anodized Cerakote Coating | Timber | 2+1x12/89 Extendable | Trigger Safety | Special Polyurethane | Trigger Safety, Automatic Locking System, Anti-Repeat System | Fiber Optic Sight | Special Polyurethane Pad |
| Redstone Super Magnum Camo Max5 | 12 GA 3.5" | 89 mm | Kinetic Drive Inertial System Semiautomatic, Rotating Bolt | 61-66-71-76 cm | Chrome-Lined, 4140 Steel Inter Bored Barrel | 5 InterPro C-IC-M-IM-F | 8 mm / High Rib | 340 mm | 55±1 mm, 45-50-60 mm Adjustable | 37±1 mm | 3.10± kg | Camo Max5 | Aluminium Anodized Camo Max5 Coating | Camo Max5 | 2+1x12/89 Extendable | Trigger Safety | Special Polyurethane | Trigger Safety, Automatic Locking System, Anti-Repeat System | Fiber Optic Sight | Special Polyurethane Pad |



OVER/UNDER

aselkon
prosport

the most
COMFORT POWER

INERTIA
TECHNOLOGY

1500
BAR



INTER.
BALANCED

INTERPROCHOKE

INTERBORED BARREL

COMFORT
RECOIL

LUXURY
WOOD



ASK 22 Black



ASK 22 Silver



ASK 22 Bronze



ASK 22 Tempered



Gauge



Chamber



Extraction System

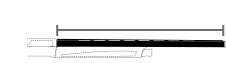

Barrel length



Barrel



Choke



Rib



Stock length



Drop at heel



Drop at comb



Weight



Forend



Receiver



Stock

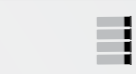

Magazine Capacity



Safety



Trigger Guard



Trigger

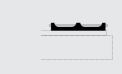

Sight



Recoil Pad

| | Gauge | Chamber | Extraction System | Barrel length | Barrel | Choke | Rib | Stock length | Drop at heel | Drop at comb | Weight | Forend | Receiver | Stock | Magazine Capacity | Safety | Trigger Guard | Trigger | Sight | Recoil Pad |
|-----------------|----------|---------|-------------------|---------------|---|------------------------|------|--------------|---------------------------------|--------------|----------|----------------------|----------------------------------|----------------------|-------------------|----------------|---------------|--|-----------------------|--------------------------|
| ASK-22 BLACK | 12 GA 3" | 76 mm | Extractor | 61-66-71-76 | Chrome-Lined, 4140 Steel Inter Bored O/U Barrel | 5 InterPro C-IC-M-IM-F | 8 mm | 340 mm | 55±1 mm, 45-50-60 mm Adjustable | 37±1 mm | 3.00± kg | Turkish Luxry Walnut | 4140 Forged Steel/ Chrome Coated | Turkish Luxry Walnut | 2 (O/U) | Trigger Safety | Steel | Single Selective O/U - Colour Options: Silver-Black-Gold | Fiberoptic Rear Sight | Special Polyurethane Pad |
| ASK-22 SILVER | 12 GA 3" | 76 mm | Extractor | 61-66-71-76 | Chrome-Lined, 4140 Steel Inter Bored O/U Barrel | 5 InterPro C-IC-M-IM-F | 8 mm | 340 mm | 55±1 mm, 45-50-60 mm Adjustable | 37±1 mm | 3.00± kg | Turkish Luxry Walnut | 4140 Forged Steel/ Chrome Coated | Turkish Luxry Walnut | 2 (O/U) | Trigger Safety | Steel | Single Selective O/U - Colour Options: Silver-Black-Gold | Fiberoptic Rear Sight | Special Polyurethane Pad |
| ASK-22 BRONZE | 12 GA 3" | 76 mm | Extractor | 61-66-71-76 | Chrome-Lined, 4140 Steel Inter Bored O/U Barrel | 5 InterPro C-IC-M-IM-F | 8 mm | 340 mm | 55±1 mm, 45-50-60 mm Adjustable | 37±1 mm | 3.00± kg | Turkish Luxry Walnut | 4140 Forged Steel/ Chrome Coated | Turkish Luxry Walnut | 2 (O/U) | Trigger Safety | Steel | Single Selective O/U - Colour Options: Silver-Black-Gold | Fiberoptic Rear Sight | Special Polyurethane Pad |
| ASK-22 TEMPERED | 12 GA 3" | 76 mm | Extractor | 61-66-71-76 | Chrome-Lined, 4140 Steel Inter Bored O/U Barrel | 5 InterPro C-IC-M-IM-F | 8 mm | 340 mm | 55±1 mm, 45-50-60 mm Adjustable | 37±1 mm | 3.00± kg | Turkish Luxry Walnut | 4140 Forged Steel/ Chrome Coated | Turkish Luxry Walnut | 2 (O/U) | Trigger Safety | Steel | Single Selective O/U - Colour Options: Silver-Black-Gold | Fiberoptic Rear Sight | Special Polyurethane Pad |



ASK 23 Black



ASK 23 Silver



ASK 23 Bronze



ASK 23 Tempered



Gauge

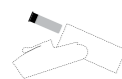

Chamber



Extraction System

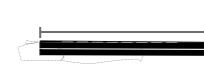

Barrel length



Barrel



Choke



Rib



Stock length



Drop at heel



Drop at comb



Weight



Forend



Receiver



Stock

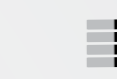

Magazine Capacity



Safety



Trigger Guard

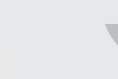

Trigger



Sight



Recoil Pad

| | Gauge | Chamber | Extraction System | Barrel length | Barrel | Choke | Rib | Stock length | Drop at heel | Drop at comb | Weight | Forend | Receiver | Stock | Magazine Capacity | Safety | Trigger Guard | Trigger | Sight | Recoil Pad |
|-----------------|----------|---------|-------------------|---------------|---|------------------------|------|--------------|---------------------------------|--------------|----------|----------------------|----------------------------------|----------------------|-------------------|----------------|---------------|--|-----------------------|--------------------------|
| ASK-23 BLACK | 12 GA 3" | 76 mm | Automatic Ejector | 61-66-71-76 | Chrome-Lined, 4140 Steel Inter Bored O/U Barrel | 5 InterPro C-IC-M-IM-F | 8 mm | 340 mm | 55±1 mm, 45-50-60 mm Adjustable | 37±1 mm | 3.00± kg | Turkish Luxry Walnut | 4140 Forged Steel/ Chrome Coated | Turkish Luxry Walnut | 2 (O/U) | Trigger Safety | Steel | Single Selective O/U - Colour Options: Silver-Black-Gold | Fiberoptic Rear Sight | Special Polyurethane Pad |
| ASK-23 SILVER | 12 GA 3" | 76 mm | Automatic Ejector | 61-66-71-76 | Chrome-Lined, 4140 Steel Inter Bored O/U Barrel | 5 InterPro C-IC-M-IM-F | 8 mm | 340 mm | 55±1 mm, 45-50-60 mm Adjustable | 37±1 mm | 3.00± kg | Turkish Luxry Walnut | 4140 Forged Steel/ Chrome Coated | Turkish Luxry Walnut | 2 (O/U) | Trigger Safety | Steel | Single Selective O/U - Colour Options: Silver-Black-Gold | Fiberoptic Rear Sight | Special Polyurethane Pad |
| ASK-23 BRONZE | 12 GA 3" | 76 mm | Automatic Ejector | 61-66-71-76 | Chrome-Lined, 4140 Steel Inter Bored O/U Barrel | 5 InterPro C-IC-M-IM-F | 8 mm | 340 mm | 55±1 mm, 45-50-60 mm Adjustable | 37±1 mm | 3.00± kg | Turkish Luxry Walnut | 4140 Forged Steel/ Chrome Coated | Turkish Luxry Walnut | 2 (O/U) | Trigger Safety | Steel | Single Selective O/U - Colour Options: Silver-Black-Gold | Fiberoptic Rear Sight | Special Polyurethane Pad |
| ASK-23 TEMPERED | 12 GA 3" | 76 mm | Automatic Ejector | 61-66-71-76 | Chrome-Lined, 4140 Steel Inter Bored O/U Barrel | 5 InterPro C-IC-M-IM-F | 8 mm | 340 mm | 55±1 mm, 45-50-60 mm Adjustable | 37±1 mm | 3.00± kg | Turkish Luxry Walnut | 4140 Forged Steel/ Chrome Coated | Turkish Luxry Walnut | 2 (O/U) | Trigger Safety | Steel | Single Selective O/U - Colour Options: Silver-Black-Gold | Fiberoptic Rear Sight | Special Polyurethane Pad |



TACTICAL



TACTICAL

the most
COMFORT POWER

- INERTIA TECHNOLOGY
- 1500 BAR
- EASY LOAD
- INTER. BALANCED
- INTERPROCHOKE
- INTERBORED BARREL
- COMFORT RECOIL



IT 1-G-EXTRA BLACK



IT 1-EXTRA BLACK



IT 1-G-BOTTOMLAND BRONZ













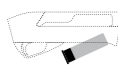
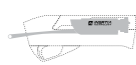
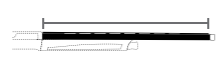





IT 1-G-BOTTOMLAND



IT 1-GV-EXTRA BLACK



IT 1-GV-BOTTOMLAND

| |  Gauge |  Chamber |  Action |  Barrel length |  Barrel |  Choke |  Rib |  Stock length |  Drop at heel |  Drop at comb |  Weight |  Forend |  Receiver |  Stock |  Magazine Capacity |  Safety |  Trigger Guard |  Trigger |  Sight |  Recoil Pad |
|----------------------------------|---|---|--|--|--|---|---|--|--|--|--|--|--|---|---|--|---|---|---|--|
| IT1 EXTRA BLACK SEMI-AUTOMATIC | 12 GA 3" | 76 mm | Kinetic Drive Inertial System Semiautomatic, Rotating Bolt | 47-61-66 cm | Chrome-Lined, 4140 Steel Inter Bored Barrel | 1 InterPro C | Tactical | 340 mm | 55±1 mm, 45-50-60 mm Adjustable | 37±1 mm | 2.85± kg | Synthetic | Aluminium Anodized/ Cerakote Coating | Synthetic | 4+1 | Trigger Safety | Special Polyurethane | Trigger Safety, Automatic Locking System, Anti-Repeat System | Tactical Sight, Ghost Ring Rear Sight | Special Polyurethane Pad |
| IT1-G EXTRA BLACK SEMI-AUTOMATIC | 12 GA 3" | 76 mm | Kinetic Drive Inertial System Semiautomatic, Rotating Bolt | 47-61-66 cm | Chrome-Lined, 4140 Steel Inter Bored Barrel | 1 InterPro C | Tactical | 340 mm | 55±1 mm, 45-50-60 mm Adjustable | 37±1 mm | 2.85± kg | Synthetic | Aluminium Anodized/ Cerakote Coating | Synthetic | 4+1 | Trigger Safety | Special Polyurethane | Trigger Safety, Automatic Locking System, Anti-Repeat System | Tactical Sight, Ghost Ring Rear Sight | Special Polyurethane Pad |
| IT1-G BOTTOMLAND | 12 GA 3" | 76 mm | Kinetic Drive Inertial System Semiautomatic, Rotating Bolt | 47-61-66 cm | Chrome-Lined, 4140 Steel Inter Bored Barrel | 1 InterPro C | Tactical | 340 mm | 55±1 mm, 45-50-60 mm Adjustable | 37±1 mm | 2.85± kg | Bottomland | Aluminium Anodized/ Bottomland Coating | Bottomland | 4+1 | Trigger Safety | Special Polyurethane | Trigger Safety, Automatic Locking System, Anti-Repeat System | Tactical Sight, Ghost Ring Rear Sight | Special Polyurethane Pad |
| IT1-G BOTTOMLAND BRONZE | 12 GA 3" | 76 mm | Kinetic Drive Inertial System Semiautomatic, Rotating Bolt | 47-61-66 cm | Chrome-Lined, 4140 Steel Inter Bored Barrel | 1 InterPro C | Tactical | 340 mm | 55±1 mm, 45-50-60 mm Adjustable | 37±1 mm | 2.85± kg | Bottomland | Aluminium Anodized/ Cerakote Coating | Bottomland | 4+1 | Trigger Safety | Special Polyurethane | Trigger Safety, Automatic Locking System, Anti-Repeat System | Tactical Sight, Ghost Ring Rear Sight | Special Polyurethane Pad |
| IT1-GV EXTRA BLACK | 12 GA 3" | 76 mm | Kinetic Drive Inertial System Semiautomatic, Rotating Bolt | 47-61-66 cm | Chrome-Lined, 4140 Steel Inter Bored Barrel | 1 InterPro C | Tactical | 340 mm | 55±1 mm, 45-50-60 mm Adjustable | 37±1 mm | 2.85± kg | Synthetic | Aluminium Anodized/ Cerakote Coating | Synthetic | 4+1 | Trigger Safety | Special Polyurethane | Trigger Safety, Automatic Locking System, Anti-Repeat System | Fiber Optic Sight | Special Polyurethane Pad |
| IT1-GV BOTTOMLAND | 12 GA 3" | 76 mm | Kinetic Drive Inertial System Semiautomatic, Rotating Bolt | 47-61-66 cm | Chrome-Lined, 4140 Steel Inter Bored Barrel | 1 InterPro C | 8 mm | 340 mm | 55±1 mm, 45-50-60 mm Adjustable | 37±1 mm | 2.85± kg | Bottomland | Aluminium Anodized/ Bottomland Coating | Bottomland | 4+1 | Trigger Safety | Special Polyurethane | Trigger Safety, Automatic Locking System, Anti-Repeat System | Fiber Optic Sight | Special Polyurethane Pad |

STATO4 MODELS

HYBRID



the most
COMFORT POWER

INERTIA
TECHNOLOGY

1500
BAR

EASY
LOAD

INTER
BALANCED

INTERPROCHOKE

INTERBORED BARREL

COMFORT
RECOIL



HYBRID SYSTEM

Gas powered automatic system. It consists of a self-regulating gas system with a short-stroke piston. It is placed at the bottom of the chamber, near the chamber, to use the hottest gases at a higher pressure.

Gases exiting the barrel expand (in the self-adjusting gas system) and rapidly accelerate the stroke of the piston, which simultaneously strikes the bolt follower pin and pushes it hard enough to cause it to retract. The gas inlet valve is self-regulating as it acts as a regulating valve that expels excess gas during ignition.

The larger the volume of gas flowing through the barrel, the faster the pin valve opens and lets it out, thereby reducing the pressure inside. Self-adjusting, it guarantees shooting accuracy, reliability, durability and certifies Aselkon's technological excellence.



TWIN PISTON/ DOUBLE PISTON

The pistons are required to move only 1/2" for complete cycling which results in a faster operation with minimum vibration and quick target acquisition.

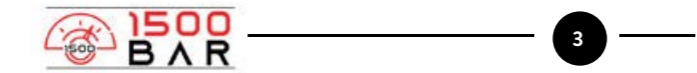

Each Aselkon barrel is subjected to a proof test with 1500 BAR high pressure test cartridge before leaving our factory.

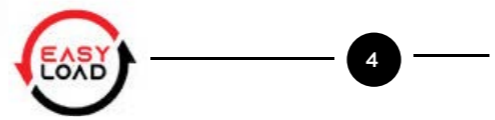

The receiver is fitted with a generously sized charging handle and bolt release as well as a beveled loading port with an outward angled cartridge drop lever insuring the inter is easy to operate even with gloved hands.



INTERPROCHOKE

We engineered the interchangeable InterPro Chokes to maximize the constancy of shot placement through reduced friction that enhances load speeds.

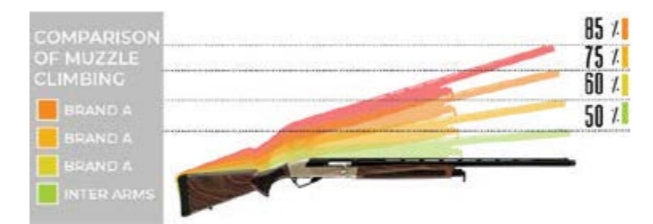

The center of gravity is balanced on the forend to ensure a comfortable carry and practical shooting.

INTERBORED BARREL

Aselkon barrels are standard with our precision drilling, honing and chrome coating process. Aselkon Barrels are designed to increase accuracy, to shoot comfortably and function superbly with both light and heavy loads.



The recoil pad is designed for comfort and fast shouldering with high tech microcell material. It's not only a shotgun, it's an experience.

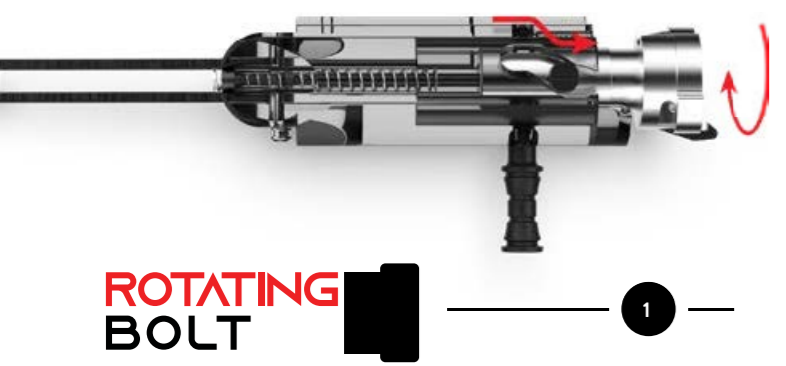



STATO 4 EXTRA BLACK



STATO 4-G-EXTRA BLACK



STATO 4-GT-EXTRA BLACK



STATO 4 SANDSTORM



STATO 4-G-SANDSTORM



STATO 4-GT-SANDSTORM



STATO 4 TITANIUM



STATO 4 NATO GREEN



STATO 4-G-TITANIUM



STATO 4-G-NATO GREEN



STATO 4-GT-TITANIUM



STATO 4-GT-NATO GREEN

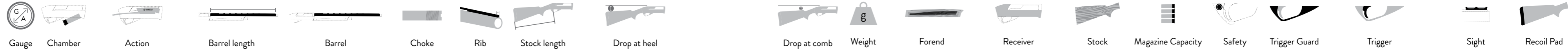

| | Gauge | Chamber | Action | Barrel length | Barrel | Choke | Rib | Stock length | Drop at heel | Drop at comb | Weight | Forend | Receiver | Stock | Magazine Capacity | Safety | Trigger Guard | Trigger | Sight | Recoil Pad |
|--------------------|----------|---------|---|---------------|---|--------------|----------|------------------------|---------------------------------|--------------|----------|-----------|--------------------------------------|----------------------|-------------------|----------------|----------------------|--|---------------------------------------|--------------------------|
| STATO4Black | 12 GA 3" | 76 mm | Hybrid System, Twin Piston Gas Operated | 47 Cm | Chrome-Lined, 4140 Steel Inter Bored Barrel | 1 InterPro C | Tactical | 340 mm | 55±1 mm, 45-50-60 mm Adjustable | 37±1 mm | 3.55± kg | Synthetic | Aluminium Anodized/ Cerakote Coating | Synthetic | 5+1 / 7+1 x 12/76 | Trigger Safety | Special Polyurethane | Trigger Safety, Automatic Locking System, Anti-Repeat System | Tactical Sight, Ghost Ring Rear Sight | Special Polyurethane Pad |
| STATO4-GBlack | 12 GA 3" | 76 mm | Hybrid System, Twin Piston Gas Operated | 47 Cm | Chrome-Lined, 4140 Steel Inter Bored Barrel | 1 InterPro C | Tactical | 340 mm | 55±1 mm, 45-50-60 mm Adjustable | 37±1 mm | 3.55± kg | Synthetic | Aluminium Anodized/ Cerakote Coating | Tactical Pistol Grip | 5+1 / 7+1 x 12/76 | Trigger Safety | Special Polyurethane | Trigger Safety, Automatic Locking System, Anti-Repeat System | Tactical Sight, Ghost Ring Rear Sight | Special Polyurethane Pad |
| STATO4-GTBlack | 12 GA 3" | 76 mm | Hybrid System, Twin Piston Gas Operated | 47 Cm | Chrome-Lined, 4140 Steel Inter Bored Barrel | 1 InterPro C | Tactical | Telescopic -Adjustable | 55±1 mm, 45-50-60 mm Adjustable | 37±1 mm | 3.55± kg | Synthetic | Aluminium Anodized/ Cerakote Coating | Tactical Telescopic | 5+1 / 7+1 x 12/76 | Trigger Safety | Special Polyurethane | Trigger Safety, Automatic Locking System, Anti-Repeat System | Tactical Sight, Ghost Ring Rear Sight | Special Polyurethane Pad |
| STATO4Sandstorm | 12 GA 3" | 76 mm | Hybrid System, Twin Piston Gas Operated | 47 Cm | Chrome-Lined, 4140 Steel Inter Bored Barrel | 1 InterPro C | Tactical | 340 mm | 55±1 mm, 45-50-60 mm Adjustable | 37±1 mm | 3.55± kg | Synthetic | Aluminium Anodized/ Cerakote Coating | Synthetic | 5+1 / 7+1 x 12/76 | Trigger Safety | Special Polyurethane | Trigger Safety, Automatic Locking System, Anti-Repeat System | Tactical Sight, Ghost Ring Rear Sight | Special Polyurethane Pad |
| STATO4-GSandstorm | 12 GA 3" | 76 mm | Hybrid System, Twin Piston Gas Operated | 47 Cm | Chrome-Lined, 4140 Steel Inter Bored Barrel | 1 InterPro C | Tactical | 340 mm | 55±1 mm, 45-50-60 mm Adjustable | 37±1 mm | 3.55± kg | Synthetic | Aluminium Anodized/ Cerakote Coating | Tactical Pistol Grip | 5+1 / 7+1 x 12/76 | Trigger Safety | Special Polyurethane | Trigger Safety, Automatic Locking System, Anti-Repeat System | Tactical Sight, Ghost Ring Rear Sight | Special Polyurethane Pad |
| STATO4-GTSandstorm | 12 GA 3" | 76 mm | Hybrid System, Twin Piston Gas Operated | 47 Cm | Chrome-Lined, 4140 Steel Inter Bored Barrel | 1 InterPro C | Tactical | Telescopic -Adjustable | 55±1 mm, 45-50-60 mm Adjustable | 37±1 mm | 3.55± kg | Synthetic | Aluminium Anodized/ Cerakote Coating | Tactical Telescopic | 5+1 / 7+1 x 12/76 | Trigger Safety | Special Polyurethane | Trigger Safety, Automatic Locking System, Anti-Repeat System | Tactical Sight, Ghost Ring Rear Sight | Special Polyurethane Pad |
| STATO4NatoGreen | 12 GA 3" | 76 mm | Hybrid System, Twin Piston Gas Operated | 47 Cm | Chrome-Lined, 4140 Steel Inter Bored Barrel | 1 InterPro C | Tactical | 340 mm | 55±1 mm, 45-50-60 mm Adjustable | 37±1 mm | 3.55± kg | Synthetic | Aluminium Anodized/ Cerakote Coating | Synthetic | 5+1 / 7+1 x 12/76 | Trigger Safety | Special Polyurethane | Trigger Safety, Automatic Locking System, Anti-Repeat System | Tactical Sight, Ghost Ring Rear Sight | Special Polyurethane Pad |
| STATO4-GNatoGreen | 12 GA 3" | 76 mm | Hybrid System, Twin Piston Gas Operated | 47 Cm | Chrome-Lined, 4140 Steel Inter Bored Barrel | 1 InterPro C | Tactical | 340 mm | 55±1 mm, 45-50-60 mm Adjustable | 37±1 mm | 3.55± kg | Synthetic | Aluminium Anodized/ Cerakote Coating | Tactical Pistol Grip | 5+1 / 7+1 x 12/76 | Trigger Safety | Special Polyurethane | Trigger Safety, Automatic Locking System, Anti-Repeat System | Tactical Sight, Ghost Ring Rear Sight | Special Polyurethane Pad |
| STATO4-GTNatoGreen | 12 GA 3" | 76 mm | Hybrid System, Twin Piston Gas Operated | 47 Cm | Chrome-Lined, 4140 Steel Inter Bored Barrel | 1 InterPro C | Tactical | Telescopic -Adjustable | 55±1 mm, 45-50-60 mm Adjustable | 37±1 mm | 3.55± kg | Synthetic | Aluminium Anodized/ Cerakote Coating | Tactical Telescopic | 5+1 / 7+1 x 12/76 | Trigger Safety | Special Polyurethane | Trigger Safety, Automatic Locking System, Anti-Repeat System | Tactical Sight, Ghost Ring Rear Sight | Special Polyurethane Pad |
| STATO4Titanium | 12 GA 3" | 76 mm | Hybrid System, Twin Piston Gas Operated | 47 Cm | Chrome-Lined, 4140 Steel Inter Bored Barrel | 1 InterPro C | Tactical | 340 mm | 55±1 mm, 45-50-60 mm Adjustable | 37±1 mm | 3.55± kg | Synthetic | Aluminium Anodized/ Cerakote Coating | Synthetic | 5+1 / 7+1 x 12/76 | Trigger Safety | Special Polyurethane | Trigger Safety, Automatic Locking System, Anti-Repeat System | Tactical Sight, Ghost Ring Rear Sight | Special Polyurethane Pad |
| STATO4-GTitanium | 12 GA 3" | 76 mm | Hybrid System, Twin Piston Gas Operated | 47 Cm | Chrome-Lined, 4140 Steel Inter Bored Barrel | 1 InterPro C | Tactical | 340 mm | 55±1 mm, 45-50-60 mm Adjustable | 37±1 mm | 3.55± kg | Synthetic | Aluminium Anodized/ Cerakote Coating | Tactical Pistol Grip | 5+1 / 7+1 x 12/76 | Trigger Safety | Special Polyurethane | Trigger Safety, Automatic Locking System, Anti-Repeat System | Tactical Sight, Ghost Ring Rear Sight | Special Polyurethane Pad |
| STATO4-GTTitanium | 12 GA 3" | 76 mm | Hybrid System, Twin Piston Gas Operated | 47 Cm | Chrome-Lined, 4140 Steel Inter Bored Barrel | 1 InterPro C | Tactical | Telescopic -Adjustable | 55±1 mm, 45-50-60 mm Adjustable | 37±1 mm | 3.55± kg | Synthetic | Aluminium Anodized/ Cerakote Coating | Tactical Telescopic | 5+1 / 7+1 x 12/76 | Trigger Safety | Special Polyurethane | Trigger Safety, Automatic Locking System, Anti-Repeat System | Tactical Sight, Ghost Ring Rear Sight | Special Polyurethane Pad |



STATO3 MODELS

HYBRID



the most
COMFORT POWER

- INERTIA TECHNOLOGY
- 1500 BAR
- EASY LOAD
- INTER-BALANCED
- INTERPROCHOKE
- INTERBORED BARREL
- COMFORT RECOIL



7

1

2

3

6

4

8

2

5

ROTATING BOLT

1



EXTRA RAIL

The new forearm with multi rail system allows the mount of mini-rails (5-slots) all over at 3/6/9/12 o'clock.

2



The receiver is fitted with a generously sized charging handle and bolt release as well as a beveled loading port with an outward angled cartridge drop lever insuring the inter is easy to operate even with gloved hands.

3



Each Aselkon barrel is subjected to a proof test with 1500 BAR high pressure test cartridge before leaving our factory.

4



INTERPROCHOKE

We engineered the interchangeable InterPro Chokes to maximize the constancy of shot placement through reduced friction that enhances load speeds.

5

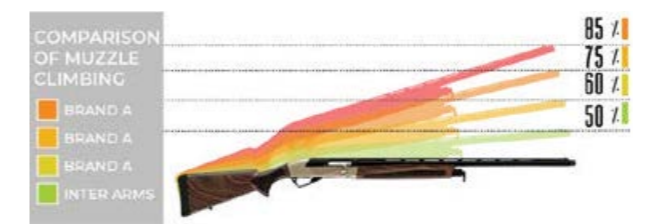

.INTER. BALANCED

The center of gravity is balanced on the forend to ensure a comfortable carry and practical shooting.

6



COMFORT RECOIL

The recoil pad is designed for comfort and fast shouldering with high tech microcell material. It's not only a shotgun, it's an experience.

7

HYBRID SYSTEM

S3 is a pump action: S3 is one of the best possible choice for any operational or defense requirement. This is thanks to its flexible use (lethal and less than lethal ammos), easy handling, precision and high firing volume.

The interchangeable stocks-fixed drop, variable drop and pistol grip-only increase the versatility of this weapon.



STATO 3 EXTRA BLACK



STATO 3-G-EXTRA BLACK



STATO 3-GT-EXTRA BLACK



STATO 3 SANDSTORM



STATO 3-G-SANDSTORM



STATO 3-GT-SANDSTORM





STATO 3 TITANIUM



STATO 3 NATO GREEN



STATO 3-G-TITANIUM



STATO 3-G-NATO GREEN



STATO 3-GT-TITANIUM



STATO 3-GT-NATO GREEN



| | Gauge | Chamber | Action | Barrel length | Barrel | Choke | Rib | Stock length | Drop at heel | Drop at comb | Weight | Forend | Receiver | Stock | Magazine Capacity | Safety | Trigger Guard | Trigger | Sight | Recoil Pad |
|-----------------------|----------|---------|--------------------|---------------|---|--------------|----------|------------------------|---------------------------------|--------------|----------|-----------|--------------------------------------|----------------------|-------------------|----------------|----------------------|--|---------------------------------------|--------------------------|
| STATO 3 Black | 12 GA 3" | 76 mm | Hybrid Pump Action | 47 Cm | Chrome-Lined, 4140 Steel Inter Bored Barrel | 1 InterPro C | Tactical | 340 mm | 55±1 mm, 45-50-60 mm Adjustable | 37±1 mm | 3.55± kg | Synthetic | Aluminium Anodized/ Cerakote Coating | Synthetic | 5+1 / 7+1 x 12/76 | Trigger Safety | Special Polyurethane | Trigger Safety, Automatic Locking System, Anti-Repeat System | Tactical Sight, Ghost Ring Rear Sight | Special Polyurethane Pad |
| STATO 3-G Black | 12 GA 3" | 76 mm | Hybrid Pump Action | 47 Cm | Chrome-Lined, 4140 Steel Inter Bored Barrel | 1 InterPro C | Tactical | 340 mm | 55±1 mm, 45-50-60 mm Adjustable | 37±1 mm | 3.55± kg | Synthetic | Aluminium Anodized/ Cerakote Coating | Tactical Pistol Grip | 5+1 / 7+1 x 12/76 | Trigger Safety | Special Polyurethane | Trigger Safety, Automatic Locking System, Anti-Repeat System | Tactical Sight, Ghost Ring Rear Sight | Special Polyurethane Pad |
| STATO 3-GT Black | 12 GA 3" | 76 mm | Hybrid Pump Action | 47 Cm | Chrome-Lined, 4140 Steel Inter Bored Barrel | 1 InterPro C | Tactical | Telescopic -Adjustable | 55±1 mm, 45-50-60 mm Adjustable | 37±1 mm | 3.55± kg | Synthetic | Aluminium Anodized/ Cerakote Coating | Tactical Telescopic | 5+1 / 7+1 x 12/76 | Trigger Safety | Special Polyurethane | Trigger Safety, Automatic Locking System, Anti-Repeat System | Tactical Sight, Ghost Ring Rear Sight | Special Polyurethane Pad |
| STATO 3 Sandstorm | 12 GA 3" | 76 mm | Hybrid Pump Action | 47 Cm | Chrome-Lined, 4140 Steel Inter Bored Barrel | 1 InterPro C | Tactical | 340 mm | 55±1 mm, 45-50-60 mm Adjustable | 37±1 mm | 3.55± kg | Synthetic | Aluminium Anodized/ Cerakote Coating | Synthetic | 5+1 / 7+1 x 12/76 | Trigger Safety | Special Polyurethane | Trigger Safety, Automatic Locking System, Anti-Repeat System | Tactical Sight, Ghost Ring Rear Sight | Special Polyurethane Pad |
| STATO 3-G Sandstorm | 12 GA 3" | 76 mm | Hybrid Pump Action | 47 Cm | Chrome-Lined, 4140 Steel Inter Bored Barrel | 1 InterPro C | Tactical | 340 mm | 55±1 mm, 45-50-60 mm Adjustable | 37±1 mm | 3.55± kg | Synthetic | Aluminium Anodized/ Cerakote Coating | Tactical Pistol Grip | 5+1 / 7+1 x 12/76 | Trigger Safety | Special Polyurethane | Trigger Safety, Automatic Locking System, Anti-Repeat System | Tactical Sight, Ghost Ring Rear Sight | Special Polyurethane Pad |
| STATO 3-GT Sandstorm | 12 GA 3" | 76 mm | Hybrid Pump Action | 47 Cm | Chrome-Lined, 4140 Steel Inter Bored Barrel | 1 InterPro C | Tactical | Telescopic -Adjustable | 55±1 mm, 45-50-60 mm Adjustable | 37±1 mm | 3.55± kg | Synthetic | Aluminium Anodized/ Cerakote Coating | Tactical Telescopic | 5+1 / 7+1 x 12/76 | Trigger Safety | Special Polyurethane | Trigger Safety, Automatic Locking System, Anti-Repeat System | Tactical Sight, Ghost Ring Rear Sight | Special Polyurethane Pad |
| STATO 3 Nato Green | 12 GA 3" | 76 mm | Hybrid Pump Action | 47 Cm | Chrome-Lined, 4140 Steel Inter Bored Barrel | 1 InterPro C | Tactical | 340 mm | 55±1 mm, 45-50-60 mm Adjustable | 37±1 mm | 3.55± kg | Synthetic | Aluminium Anodized/ Cerakote Coating | Synthetic | 5+1 / 7+1 x 12/76 | Trigger Safety | Special Polyurethane | Trigger Safety, Automatic Locking System, Anti-Repeat System | Tactical Sight, Ghost Ring Rear Sight | Special Polyurethane Pad |
| STATO 3-G Nato Green | 12 GA 3" | 76 mm | Hybrid Pump Action | 47 Cm | Chrome-Lined, 4140 Steel Inter Bored Barrel | 1 InterPro C | Tactical | 340 mm | 55±1 mm, 45-50-60 mm Adjustable | 37±1 mm | 3.55± kg | Synthetic | Aluminium Anodized/ Cerakote Coating | Tactical Pistol Grip | 5+1 / 7+1 x 12/76 | Trigger Safety | Special Polyurethane | Trigger Safety, Automatic Locking System, Anti-Repeat System | Tactical Sight, Ghost Ring Rear Sight | Special Polyurethane Pad |
| STATO 3-GT Nato Green | 12 GA 3" | 76 mm | Hybrid Pump Action | 47 Cm | Chrome-Lined, 4140 Steel Inter Bored Barrel | 1 InterPro C | Tactical | Telescopic -Adjustable | 55±1 mm, 45-50-60 mm Adjustable | 37±1 mm | 3.55± kg | Synthetic | Aluminium Anodized/ Cerakote Coating | Tactical Telescopic | 5+1 / 7+1 x 12/76 | Trigger Safety | Special Polyurethane | Trigger Safety, Automatic Locking System, Anti-Repeat System | Tactical Sight, Ghost Ring Rear Sight | Special Polyurethane Pad |
| STATO 3 Titanium | 12 GA 3" | 76 mm | Hybrid Pump Action | 47 Cm | Chrome-Lined, 4140 Steel Inter Bored Barrel | 1 InterPro C | Tactical | 340 mm | 55±1 mm, 45-50-60 mm Adjustable | 37±1 mm | 3.55± kg | Synthetic | Aluminium Anodized/ Cerakote Coating | Synthetic | 5+1 / 7+1 x 12/76 | Trigger Safety | Special Polyurethane | Trigger Safety, Automatic Locking System, Anti-Repeat System | Tactical Sight, Ghost Ring Rear Sight | Special Polyurethane Pad |
| STATO 3-G Titanium | 12 GA 3" | 76 mm | Hybrid Pump Action | 47 Cm | Chrome-Lined, 4140 Steel Inter Bored Barrel | 1 InterPro C | Tactical | 340 mm | 55±1 mm, 45-50-60 mm Adjustable | 37±1 mm | 3.55± kg | Synthetic | Aluminium Anodized/ Cerakote Coating | Tactical Pistol Grip | 5+1 / 7+1 x 12/76 | Trigger Safety | Special Polyurethane | Trigger Safety, Automatic Locking System, Anti-Repeat System | Tactical Sight, Ghost Ring Rear Sight | Special Polyurethane Pad |
| STATO 3-GT Titanium | 12 GA 3" | 76 mm | Hybrid Pump Action | 47 Cm | Chrome-Lined, 4140 Steel Inter Bored Barrel | 1 InterPro C | Tactical | Telescopic -Adjustable | 55±1 mm, 45-50-60 mm Adjustable | 37±1 mm | 3.55± kg | Synthetic | Aluminium Anodized/ Cerakote Coating | Tactical Telescopic | 5+1 / 7+1 x 12/76 | Trigger Safety | Special Polyurethane | Trigger Safety, Automatic Locking System, Anti-Repeat System | Tactical Sight, Ghost Ring Rear Sight | Special Polyurethane Pad |



ASK 12



the most
COMFORT POWER

NERTIA
TECHNOLOGY

1500
BAR



INTER.
BALANCED

INTERPLUSCHOKE

INTERBOREDBARREL



ASK 12 Khaki Green



ASK 12 Black



ASK 12 Desert



Gauge

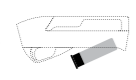

Chamber

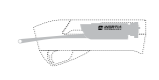

Action



Barrel length



Barrel



Choke



Rib



Stock length

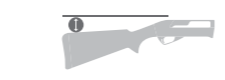

Drop at heel



Drop at comb



Weight



Forend



Receiver



Stock



Magazine Capacity



Safety



Trigger Guard



Trigger



Sight



Recoil Pad

| | Gauge | Chamber | Action | Barrel length | Barrel | Choke | Rib | Stock length | Drop at heel | Drop at comb | Weight | Forend | Receiver | Stock | Magazine Capacity | Safety | Trigger Guard | Trigger | Sight | Recoil Pad |
|--------------------|----------|---------|--------------|---------------|--------------------------------------|--------------|-----------------|--------------|---------------------------------|--------------|----------|---------|---|-------------------|-------------------|----------------|----------------------|--|--------------------------|--------------------------|
| ASK 12 DESERT | 12 GA 3" | 76 mm | GAS OPERATED | 47 Cm | Chrome-Lined, 4140 Steel Inter Bored | 1 InterPro C | 22 mm Picatinny | 340 mm | 55±1 mm, 45-50-60 mm Adjustable | 37±1 mm | 4.00± kg | Plastic | 7075-T6 Aluminum Alloy Cerakote Coating | Composite Plastic | 2+1, 5+1, 10+1 | Trigger Safety | Special Polyurethane | Trigger Safety, Automatic Locking System, Anti-Repeat System | Adjustable Folding Sight | Special Polyurethane Pad |
| ASK 12 KHAKI GREEN | 12 GA 3" | 76 mm | GAS OPERATED | 47 Cm | Chrome-Lined, 4140 Steel Inter Bored | 1 InterPro C | 22 mm Picatinny | 340 mm | 55±1 mm, 45-50-60 mm Adjustable | 37±1 mm | 4.00± kg | Plastic | 7075-T6 Aluminum Alloy Cerakote Coating | Composite Plastic | 2+1, 5+1, 10+1 | Trigger Safety | Special Polyurethane | Trigger Safety, Automatic Locking System, Anti-Repeat System | Adjustable Folding Sight | Special Polyurethane Pad |
| ASK 12 BLACK | 12 GA 3" | 76 mm | GAS OPERATED | 47 Cm | Chrome-Lined, 4140 Steel Inter Bored | 1 InterPro C | 22 mm Picatinny | 340 mm | 55±1 mm, 45-50-60 mm Adjustable | 37±1 mm | 4.00± kg | Plastic | 7075-T6 Aluminum Alloy Cerakote Coating | Composite Plastic | 2+1, 5+1, 10+1 | Trigger Safety | Special Polyurethane | Trigger Safety, Automatic Locking System, Anti-Repeat System | Adjustable Folding Sight | Special Polyurethane Pad |

PCP Air Rifles





COMFORT RECOIL

It is a shock absorbing shoulder system made of a mixture of special polyurethane and rubber materials.

ADJUSTABLE TRIGGER

Setting the trigger distances according to the finger structure of each user; (right, left, up and down trigger setting) designed to make the trigger system.



ASELKON MANO METER

Pressure gauge showing the dry air pressure inside the tube without disturbing the visibility



SLIENCER

Specially designed muffler system to provide a quieter shot opportunity



PICATINNY 2mm

Binocular rail system in Nato standards, adapted visually and aesthetically with the body



COMFORT COMB

It is a cheek system obtained from special raw material mixtures in order to prevent slipping of the cheek during aiming and to ensure comfortable aiming while maintaining the face sensitivity.

ERGONOMIC GRIP

It is a pistol grip system designed from special materials for comfort and ease of grip.

INDEX MAGAZINE

It is a magazine system designed from special materials for automatic pellet scrolling after pellet filling.





EMPERADOR LS1

EMPERADOR LS1

High precision accuracy.
 Tube can be replaceable without pressure loss.
 Improved new generation regulator enables easy and consistent setting.
 Power setting lever increase the range efficiency in use.
 Larger magazine capacity.
 Reinforced polymer stock with ergonomic rubber grip.
 Foldable Tactical Stock, adjustable cheek riser and recoil pad.

MX MAGAZINE

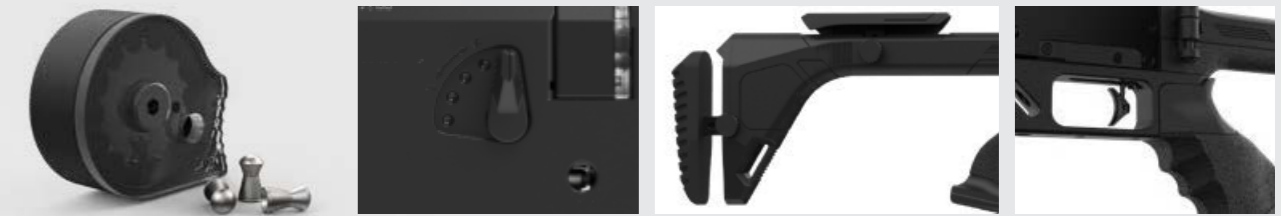

| Caliber | Regulator | Muzzle Output Speed* | Power (Joule) | Magazine Capacity | Tube Volume | Filling Pressure | Number of Shots | Stock | Total Length | Barrel Length | Type of Barrel | Twist Rate | Weight | Scope Rail | Replacement Magazine | Colour Option | Case |
|-------------------|-----------------|----------------------|---------------|-------------------|-------------|------------------|-----------------|----------|-----------------|---------------|----------------|------------|--------------------|---------------------|----------------------|----------------------------|------------------|
| 4.5 mm / .177cal | Regulated 22 cc | 940 FPS | 24 J | 22 | 260 cc | 200 bar | 90 | Tactical | 1020 mm (40.15) | 580 mm | Rifled | 1:15 | 3520 gr (7.76 lbs) | 11 mm Dovetail Rail | Yes | Matte Black / Glossy Black | Plastic Hardcase |
| 5.5 mm / .22 cal | Regulated 22 cc | 910 FPS | 41 J | 18 | 260 cc | 200 bar | 80 | Tactical | 1020 mm (40.15) | 580 mm | Rifled | 1:15 | 3520 gr (7.76 lbs) | 11 mm Dovetail Rail | Yes | Matte Black / Glossy Black | Plastic Hardcase |
| 6.35 mm / .25 cal | Regulated 22 cc | 890 FPS | 61 J | 15 | 260 cc | 200 bar | 65 | Tactical | 1020 mm (40.15) | 580 mm | Rifled | 1:15 | 3520 gr (7.76 lbs) | 11 mm Dovetail Rail | Yes | Matte Black / Glossy Black | Plastic Hardcase |



EMPERADOR LS2

EMPERADOR LS2

High precision accuracy.
 Tube can be replaceable without pressure loss.
 Improved new generation regulator enables easy and consistent setting.
 Power setting lever increase the range efficiency in use.
 Larger magazine capacity.
 Premium quality Turkish walnut stock.
 Ergonomic grip design.

MX MAGAZINE



| Caliber | Regulator & Volume | Muzzle Output Speed* | Power (Joule) | Magazine Capacity | Tube Volume | Filling Pressure | Number of Shots | Stock | Total Length | Barrel Length | Type of Barrel | Twist Rate | Weight | Scope Rail | Replacement Magazine | Colour Option | Case |
|-------------------|--------------------|----------------------|---------------|-------------------|-------------|------------------|-----------------|----------------------|---------------|---------------|----------------|------------|--------------------|----------------|----------------------|----------------------------|------------------|
| 4.5 mm / .177cal | Regulated 22 cc | 940 FPS | 24 J | 22 | 260 cc | 200 bar | 90 | Turkish Luxry Walnut | 820 mm (32.3) | 580 mm | Rifled | 1:15 | 3820 gr (8.42 lbs) | 11 mm Dovetail | Yes | Matte Black / Glossy Black | Plastic Hardcase |
| 5.5 mm / .22 cal | Regulated 22 cc | 910 FPS | 41 J | 18 | 260 cc | 200 bar | 80 | Turkish Luxry Walnut | 820 mm (32.3) | 580 mm | Rifled | 1:15 | 3820 gr (8.42 lbs) | 11 mm Dovetail | Yes | Matte Black / Glossy Black | Plastic Hardcase |
| 6.35 mm / .25 cal | Regulated 22 cc | 890 FPS | 61 J | 15 | 260 cc | 200 bar | 65 | Turkish Luxry Walnut | 820 mm (32.3) | 580 mm | Rifled | 1:15 | 3820 gr (8.42 lbs) | 11 mm Dovetail | Yes | Matte Black / Glossy Black | Plastic Hardcase |





















EMPERADOR LS3

EMPERADOR LS3

High precision accuracy.
 Tube can be replaceable without pressure loss.
 Improved new generation regulator enables easy and consistent setting.
 Power setting lever increase the range efficiency in use.
 Premium quality Turkish walnut stock.
 Larger magazine capacity.
 Adjustable cheek riser.
 Larger magazine capacity.

MX MAGAZINE



|  Caliber |  Regulator & Volume |  Muzzle Output Speed* |  Power (Joule) |  Magazine Capacity |  Tube Volume |  Filling Pressure |  Number of Shots |  Stock |  Total Length |  Barrel Length |  Type of Barrel |  Twist Rate |  Weight |  Scope Rail |  Replacement Magazine |  Colour Option |  Case |
|---|--|--|---|---|---|--|---|---|--|---|--|--|--|--|--|---|--|
| 4.5 mm / .177cal | Regulated 22 cc | 940 FPS | 24 J | 22 | 260 cc | 200 bar | 90 | Turkish Luxry Walnut | 1020 mm (40.15) | 580 mm | Rifled | 1:15 | 3600 gr (7.90 lbs) | 11 mm Dovetail Rail | Yes | Matte Black / Glossy Black | Plastic Hardcase |
| 5.5 mm / .22 cal | Regulated 22 cc | 910 FPS | 41 J | 18 | 260 cc | 200 bar | 80 | Turkish Luxry Walnut | 1020 mm (40.15) | 580 mm | Rifled | 1:15 | 3600 gr (7.90 lbs) | 11 mm Dovetail Rail | Yes | Matte Black / Glossy Black | Plastic Hardcase |
| 6.35 mm / .25 cal | Regulated 22 cc | 890 FPS | 61 J | 15 | 260 cc | 200 bar | 65 | Turkish Luxry Walnut | 1020 mm (40.15) | 580 mm | Rifled | 1:15 | 3600 gr (7.90 lbs) | 11 mm Dovetail Rail | Yes | Matte Black / Glossy Black | Plastic Hardcase |



EMPERADOR LS3

EMPERADOR LS4

High precision accuracy.
 Tube can be replaceable without pressure loss.
 Improved new generation regulator enables easy and consistent setting.
 Power setting lever increase the range efficiency in use.
 Larger magazine capacity.
 Premium quality Turkish walnut stock.



| Caliber | Regulator | Muzzle Output Speed* | Power (Joule) | Magazine Capacity | Tube Volume | Filling Pressure | Number of Shots | Stock | Total Length | Barrel Length | Type of Barrel | Twist Rate | Weight | Scope Rail | Replacement Magazine | Colour Option | Case |
|-------------------|-----------------|----------------------|---------------|-------------------|-------------|------------------|-----------------|----------------------|-----------------|---------------|----------------|------------|--------------------|---------------------|----------------------|----------------------------|------------------|
| 4.5 mm / .177cal | Regulated 22 cc | 940 FPS | 24 J | 22 | 260 cc | 200 bar | 90 | Turkish Luxry Walnut | 1020 mm (40.15) | 580 mm | Rifled | 1:15 | 3820 gr (8.42 lbs) | 11 mm Dovetail Rail | Yes | Matte Black / Glossy Black | Plastic Hardcase |
| 5.5 mm / .22 cal | Regulated 22 cc | 910 FPS | 41 J | 18 | 260 cc | 200 bar | 80 | Turkish Luxry Walnut | 1020 mm (40.15) | 580 mm | Rifled | 1:15 | 3820 gr (8.42 lbs) | 11 mm Dovetail Rail | Yes | Matte Black / Glossy Black | Plastic Hardcase |
| 6.35 mm / .25 cal | Regulated 22 cc | 890 FPS | 61 J | 15 | 260 cc | 200 bar | 65 | Turkish Luxry Walnut | 1020 mm (40.15) | 580 mm | Rifled | 1:15 | 3820 gr (8.42 lbs) | 11 mm Dovetail Rail | Yes | Matte Black / Glossy Black | Plastic Hardcase |



MX5 JET BLACK

MX5

Side lever cocking system with manual locking system. Adjustable cheek piece soft rubber coated. Rubber grip for a better control and shooting feeling Precision rifled barrel special coated. Micro adjustable rear sight for both windage and elevation Truglo Special stainless black electsol coating.



Kinetic Energy is adjustable from **3 to 60 Joules**



MX5 MATTE BLACK

| Caliber | Regulator & Volume | Muzzle Output Speed* | Power (Joule) | Magazine Capacity | Tube Volume | Filling Pressure | Number of Shots | Stock | Total Length | Barrel Length | Type of Barrel | Twist Rate | Weight | Scope Rail | Replacement Magazine | Colour Option | Case |
|-------------------|--------------------|----------------------|---------------|-------------------|-------------|------------------|-----------------|----------------------|----------------|---------------|----------------|------------|--------------------|----------------------|----------------------|----------------------------|------------------|
| 4.5 mm / .177cal | Optional | 850/900 FPS | 35 J | 14 | 320cc | 200 bar | 90 | Turkish Luxry Walnut | 1100 mm(43.30) | 550mm | Rifled | 1:15 | 3250 gr (7.16 lbs) | 22 mm Picatinny Rail | Yes | Matte Black / Glossy Balck | Plastic Hardcase |
| 5.5 mm / .22 cal | Optional | 850/970 FPS | 52 J | 12 | 320cc | 200 bar | 80 | Turkish Luxry Walnut | 1100 mm(43.30) | 550mm | Rifled | 1:15 | 3250 gr (7.16 lbs) | 22 mm Picatinny Rail | Yes | Matte Black / Glossy Balck | Plastic Hardcase |
| 6.35 mm / .25 cal | Optional | 840/890 FPS | 62 J | 10 | 320cc | 200 bar | 65 | Turkish Luxry Walnut | 1100 mm(43.30) | 550mm | Rifled | 1:15 | 3250 gr (7.16 lbs) | 22 mm Picatinny Rail | Yes | Matte Black / Glossy Balck | Plastic Hardcase |



MX6 MATTE BLACK

MX6

Side lever cocking system with manual locking system. Adjustable cheek piece soft rubber coated. Rubber grip for a better control and shooting feeling Precision rifled barrel special coated. Micro adjustable rear sight for both windage and elevation Truglo Special stainless black electsol coating.



Kinetic Energy is adjustable from **3 to 60 Joules**



MX6 JET BLACK

| Caliber | Regulator | Muzzle Output Speed* | Power (Joule) | Magazine Capacity | Tube Volume | Filling Pressure | Number of Shots | Stock | Total Length | Barrel Length | Type of Barrel | Twist Rate | Weight | Scope Rail | Replacement Magazine | Colour Option | Case |
|-------------------|-----------|----------------------|---------------|-------------------|-------------|------------------|-----------------|-----------------------|----------------|---------------|----------------|------------|--------------------|----------------------|----------------------|----------------------------|------------------|
| 4.5 mm / .177cal | Optional | 850/900 FPS | 35 J | 14 | 500 cc | 200 bar | 90 | Turkish Luxury Walnut | 1100 mm(43.30) | 550mm | Rifled | 1:15 | 3250 gr (7.16 lbs) | 22 mm Picatinny Rail | Yes | Matte Black / Glossy Balck | Plastic Hardcase |
| 5.5 mm / .22 cal | Optional | 870/950 FPS | 52 J | 12 | 500 cc | 200 bar | 80 | Turkish Luxury Walnut | 1100 mm(43.30) | 550mm | Rifled | 1:15 | 3250 gr (7.16 lbs) | 22 mm Picatinny Rail | Yes | Matte Black / Glossy Balck | Plastic Hardcase |
| 6.35 mm / .25 cal | Optional | 840/890 FPS | 62 J | 10 | 500 cc | 200 bar | 65 | Turkish Luxury Walnut | 1100 mm(43.30) | 550mm | Rifled | 1:15 | 3250 gr (7.16 lbs) | 22 mm Picatinny Rail | Yes | Matte Black / Glossy Balck | Plastic Hardcase |



MX7 BLACK

MX7

Side lever cocking system with manual locking system. Adjustable cheek piece soft rubber coated. Rubber grip for a better control and shooting feeling Precision rifled barrel special coated. Micro adjustable rear sight for both windage and elevation Truglo Special stainless black electsol coating.



Kinetic Energy is adjustable from
3 to 60 Joules



MX7 MAX5



MX7 WOOD

| Caliber | Regulator & Volume | Muzzle Output Speed* | Power (Joule) | Magazine Capacity | Tube Volume | Filling Pressure | Number of Shots | Stock | Total Length | Barrel Length | Type of Barrel | Twist Rate | Weight | Scope Rail | Replacement Magazine | Colour Option | Case |
|-------------------|--------------------|----------------------|---------------|-------------------|-------------|------------------|-----------------|--------------------------------|--------------|---------------|----------------|------------|---------|----------------------|----------------------|----------------------------|------------------|
| 4.5 mm / .177cal | Optional | 850/1100 FPS | 25 J | 14 | 320 cc | 200 bar | 80 | Turkish Luxry Walnut Synthetic | 850 mm | 550mm | Rifled | 1:15 | 2750 gr | 22 mm Picatinny Rail | Yes | Matte Black / Glossy Balck | Plastic Hardcase |
| 5.5 mm / .22 cal | Optional | 850/900 FPS | 49 J | 12 | 320 cc | 200 bar | 70 | Turkish Luxry Walnut Synthetic | 850 mm | 550mm | Rifled | 1:15 | 2750 gr | 22 mm Picatinny Rail | Yes | Matte Black / Glossy Balck | Plastic Hardcase |
| 6.35 mm / .25 cal | Optional | 840/890 FPS | 62 J | 10 | 320 cc | 200 bar | 55 | Turkish Luxry Walnut Synthetic | 850 mm | 550mm | Rifled | 1:15 | 2750 gr | 22 mm Picatinny Rail | Yes | Matte Black / Glossy Balck | Plastic Hardcase |



MX7-S MAX5

MX7-S

Side lever cocking system with manual locking system. Adjustable cheek piece soft rubber coated. Rubber grip for a better control and shooting feeling Precision rifled barrel special coated. Micro adjustable rear sight for both windage and elevation Truglo Special stainless black electsol coating.



Kinetic Energy is adjustable from **3 to 60 Joules**



MX7-S BLACK



MX7-S WOOD

| Caliber | Regulator & Volume | Muzzle Output Speed* | Power (Joule) | Magazine Capacity | Tube Volume | Filling Pressure | Number of Shots | Stock | Total Length | Barrel Length | Type of Barrel | Twist Rate | Weight | Scope Rail | Replacement Magazine | Colour Option | Case |
|-------------------|--------------------|----------------------|---------------|-------------------|-------------|------------------|-----------------|--------------------------------|--------------|---------------|----------------|------------|---------|----------------------|----------------------|----------------------------|------------------|
| 4.5 mm / .177cal | Optional | 830/880 FPS | 22 J | 14 | 275cc | 200 bar | 80 | Turkish Luxry Walnut Synthetic | 650 mm | 450 mm | Rifled | 1:15 | 2600 gr | 22 mm Picatinny Rail | Yes | Matte Black / Glossy Balck | Plastic Hardcase |
| 5.5 mm / .22 cal | Optional | 830/870 FPS | 41 J | 12 | 275cc | 200 bar | 70 | Turkish Luxry Walnut Synthetic | 650 mm | 450 mm | Rifled | 1:15 | 2600 gr | 22 mm Picatinny Rail | Yes | Matte Black / Glossy Balck | Plastic Hardcase |
| 6.35 mm / .25 cal | Optional | 800/850 FPS | 54 J | 10 | 275cc | 200 bar | 55 | Turkish Luxry Walnut Synthetic | 650 mm | 450 mm | Rifled | 1:15 | 2600 gr | 22 mm Picatinny Rail | Yes | Matte Black / Glossy Balck | Plastic Hardcase |



MX8 BLACK

MX8

Side lever cocking system with manual locking system. Adjustable cheek piece soft rubber coated. Rubber grip for a better control and shooting feeling Precision rifled barrel special coated. Micro adjustable rear sight for both windage and elevation Truglo Special stainless black eelscol coating.



Kinetic Energy is adjustable from **3 to 60 Joules**



MX8 MAX5

| Caliber | Regulator & Volume | Muzzle Output Speed* | Power (Joule) | Magazine Capacity | Tube Volume | Filling Pressure | Number of Shots | Stock | Total Length | Barrel Length | Type of Barrel | Twist Rate | Weight | Scope Rail | Replacement Magazine | Colour Option | Case |
|-------------------|--------------------|----------------------|---------------|-------------------|-------------|------------------|-----------------|-----------|--------------|---------------|----------------|------------|--------------------|----------------------|----------------------|----------------------------|------------------|
| 4.5 mm / .177cal | Optional | 800/1100 FPS | 35 J | 14 | 500 cc | 250 bar | 90 | Synthetic | 950 mm | 550 mm | Rifled | 1:15 | 3250 gr (7.16 lbs) | 22 mm Picatinny Rail | Yes | Matte Black / Glossy Black | Plastic Hardcase |
| 5.5 mm / .22 cal | Optional | 870/950 FPS | 54 J | 12 | 500 cc | 250 bar | 80 | Synthetic | 950 mm | 550 mm | Rifled | 1:15 | 3250 gr (7.16 lbs) | 22 mm Picatinny Rail | Yes | Matte Black / Glossy Black | Plastic Hardcase |
| 6.35 mm / .25 cal | Optional | 840/900 FPS | 62 J | 10 | 500 cc | 250 bar | 65 | Synthetic | 950 mm | 550 mm | Rifled | 1:15 | 3250 gr (7.16 lbs) | 22 mm Picatinny Rail | Yes | Matte Black / Glossy Black | Plastic Hardcase |



MX9 WOOD

MX9

Side lever cocking system with manual locking system. Adjustable cheek piece soft rubber coated. Rubber grip for a better control and shooting feeling Precision rifled barrel special coated. Micro adjustable rear sight for both windage and elevation Truglo Special stainless black electsol coating.



Kinetic Energy is adjustable from **3 to 62 Joules**



| Caliber | Regulator & Volume | Muzzle Output Speed* | Power (Joule) | Magazine Capacity | Tube Volume | Filling Pressure | Number of Shots | Stock | Total Length | Barrel Length | Type of Barrel | Twist Rate | Weight | Scope Rail | Replacement Magazine | Colour Option | Case |
|-------------------|--------------------|----------------------|---------------|-------------------|-------------|------------------|-----------------|----------------------|-----------------|---------------|----------------|------------|---------|----------------------|----------------------|----------------------------|------------------|
| 4.5 mm / .177cal | Optional | 800/1100 FPS | 35 J | 14 | 500 cc | 250 bar | 90 | Turkish Luxry Walnut | 1100 mm (43.30) | 550 mm | Rifled | 1:15 | 3750 gr | 22 mm Picatinny Rail | Yes | Matte Black / Glossy Black | Plastic Hardcase |
| 5.5 mm / .22 cal | Optional | 870/950 FPS | 54 J | 12 | 500 cc | 250 bar | 80 | Turkish Luxry Walnut | 1100 mm (43.30) | 550 mm | Rifled | 1:15 | 3750 gr | 22 mm Picatinny Rail | Yes | Matte Black / Glossy Black | Plastic Hardcase |
| 6.35 mm / .25 cal | Optional | 840/900 FPS | 52 J | 10 | 500 cc | 250 bar | 65 | Turkish Luxry Walnut | 1100 mm (43.30) | 550 mm | Rifled | 1:15 | 3750 gr | 22 mm Picatinny Rail | Yes | Matte Black / Glossy Black | Plastic Hardcase |



MX10 BLACK

MX10

Side lever cocking system with manual locking system. Adjustable cheek piece soft rubber coated. Rubber grip for a better control and shooting feeling Precision rifled barrel special coated. Micro adjustable rear sight for both windage and elevation Truglo Special stainless black elecsol coating.



Kinetic Energy is adjustable from **3 to 60 Joules**



MX10 MAX5



MX10 WOOD

| Caliber | Regulator & Volume | Muzzle Output Speed* | Power (Joule) | Magazine Capacity | Tube Volume | Filling Pressure | Number of Shots | Stock | Total Length | Barrel Length | Type of Barrel | Twist Rate | Weight | Scope Rail | Replacement Magazine | Colour Option | Case |
|-------------------|--------------------|----------------------|---------------|-------------------|-------------|------------------|-----------------|----------|--------------|---------------|----------------|------------|---------|----------------------|----------------------|----------------------------|------------------|
| 4.5 mm / .177cal | Optional | 830/950 FPS | 22 J | 14 | 320 | 200 bar | 80 | Syntetic | 850 mm | 550 mm | Rifled | 1:15 | 2850 gr | 22 mm Picatinny Rail | Yes | Matte Black / Glossy Black | Plastic Hardcase |
| 5.5 mm / .22 cal | Optional | 830/950 FPS | 49 J | 12 | 320 | 200 bar | 70 | Syntetic | 850 mm | 550 mm | Rifled | 1:15 | 2850 gr | 22 mm Picatinny Rail | Yes | Matte Black / Glossy Black | Plastic Hardcase |
| 6.35 mm / .25 cal | Optional | 800/850 FPS | 54 J | 10 | 320 | 200 bar | 55 | Syntetic | 850 mm | 550 mm | Rifled | 1:15 | 2850 gr | 22 mm Picatinny Rail | Yes | Matte Black / Glossy Black | Plastic Hardcase |



MX10-S BLACK

MX10-S

Side lever cocking system with manual locking system. Adjustable cheek piece soft rubber coated. Rubber grip for a better control and shooting feeling Precision rifled barrel special coated. Micro adjustable rear sight for both windage and elevation Truglo Special stainless black elecsol coating.



Kinetic Energy is adjustable from **3 to 60 Joules**



MX10-S MAX5



MX10-S WOOD

| Caliber | Regulator & Volume | Muzzle Output Speed* | Power (Joule) | Magazine Capacity | Tube Volume | Filling Pressure | Number of Shots | Stock | Total Length | Barrel Length | Type of Barrel | Twist Rate | Weight | Scope Rail | Replacement Magazine | Colour Option | Case |
|-------------------|--------------------|----------------------|---------------|-------------------|-------------|------------------|-----------------|--------------------------------|--------------|---------------|----------------|------------|---------|----------------------|----------------------|----------------------------|------------------|
| 4.5 mm / .177cal | Optional | 830/890 FPS | 22 J | 14 | 275 cc | 200 bar | 80 | Turkish Luxry Walnut Synthetic | 850 mm | 450 mm | Rifled | 1:15 | 2850 gr | 22 mm Picatinny Rail | Yes | Matte Black / Glossy Black | Plastic Hardcase |
| 5.5 mm / .22 cal | Optional | 830/870 FPS | 49 J | 12 | 275 cc | 200 bar | 70 | Turkish Luxry Walnut Synthetic | 850 mm | 450 mm | Rifled | 1:15 | 2850 gr | 22 mm Picatinny Rail | Yes | Matte Black / Glossy Black | Plastic Hardcase |
| 6.35 mm / .25 cal | Optional | 830/870 FPS | 54 J | 10 | 275 cc | 200 bar | 55 | Turkish Luxry Walnut Synthetic | 850 mm | 450 mm | Rifled | 1:15 | 2850 gr | 22 mm Picatinny Rail | Yes | Matte Black / Glossy Black | Plastic Hardcase |



PCP RAVELLO RX5

RAVELLO RX5

Side lever cocking system with manual locking system. Adjustable cheek piece soft rubber coated. Rubber grip for a better control and shooting feeling Precision rifled barrel special coated. Micro adjustable rear sight for both windage and elevation Truglo Special stainless black elescopic coating.



Kinetic Energy is adjustable from **3 to 60 Joules**



| Regulator & Volume | Muzzle Output Speed* | Power (Joule) | Magazine Capacity | Tube Volume | Filling Pressure | Number of Shots | Stock | Total Length | Barrel Length | Type of Barrel | Twist Rate | Weight | Scope Rail | Replacement Magazine | Colour Option | Case | |
|--------------------|----------------------|---------------|-------------------|-------------|------------------|-----------------|-------|----------------------|-----------------|----------------|------------|--------|------------|----------------------|---------------|----------------------------|------------------|
| 4.5 mm / .177cal | Optional | 850/900 FPS | 35 J | 14 | 320 cc | 200 bar | 90 | Turkish Luxry Walnut | 1100 mm (43.30) | 550 mm | Rifled | 1:15 | 3250 gr | 22 mm Picatinny Rail | Yes | Matte Black / Glossy Black | Plastic Hardcase |
| 5.5 mm / .22 cal | Optional | 850/970 FPS | 52 J | 12 | 320 cc | 200 bar | 80 | Turkish Luxry Walnut | 1100 mm (43.30) | 550 mm | Rifled | 1:15 | 3250 gr | 22 mm Picatinny Rail | Yes | Matte Black / Glossy Black | Plastic Hardcase |
| 6.35 mm / .25 cal | Optional | 840/890 FPS | 62 J | 10 | 320 cc | 200 bar | 65 | Turkish Luxry Walnut | 1100 mm (43.30) | 550 mm | Rifled | 1:15 | 3250 gr | 22 mm Picatinny Rail | Yes | Matte Black / Glossy Black | Plastic Hardcase |



PCP RAVELLO RX6

RAVELLO RX6

Side lever cocking system with manual locking system. Adjustable cheek piece soft rubber coated. Rubber grip for a better control and shooting feeling Precision rifled barrel special coated. Micro adjustable rear sight for both windage and elevation Truglo Special stainless black elescopic coating.



Kinetic Energy is adjustable from **3 to 60 Joules**



| Regulator & Volume | Muzzle Output Speed* | Power (Joule) | Magazine Capacity | Tube Volume | Filling Pressure | Number of Shots | Stock | Total Length | Barrel Length | Type of Barrel | Twist Rate | Weight | Scope Rail | Replacement Magazine | Colour Option | Case |
|--------------------|----------------------|---------------|-------------------|-------------|------------------|-----------------|-------|--------------|---------------|----------------|------------|--------|------------|----------------------|---------------|------|
|--------------------|----------------------|---------------|-------------------|-------------|------------------|-----------------|-------|--------------|---------------|----------------|------------|--------|------------|----------------------|---------------|------|

| | | | | | | | | | | | | | | | | | |
|-------------------|----------|-------------|------|----|--------|---------|----|----------------------|-----------------|--------|--------|------|---------|----------------------|-----|----------------------------|------------------|
| 4.5 mm / .177cal | Optional | 850/900 FPS | 35 J | 14 | 550 cc | 250 bar | 90 | Turkish Luxry Walnut | 1100 mm (43.30) | 550 mm | Rifled | 1:15 | 3750 gr | 22 mm Picatinny Rail | Yes | Matte Black / Glossy Black | Plastic Hardcase |
| 5.5 mm / .22 cal | Optional | 850/970 FPS | 52 J | 12 | 550 cc | 250 bar | 80 | Turkish Luxry Walnut | 1100 mm (43.30) | 550 mm | Rifled | 1:15 | 3750 gr | 22 mm Picatinny Rail | Yes | Matte Black / Glossy Black | Plastic Hardcase |
| 6.35 mm / .25 cal | Optional | 840/890 FPS | 62 J | 10 | 550 cc | 250 bar | 65 | Turkish Luxry Walnut | 1100 mm (43.30) | 550 mm | Rifled | 1:15 | 3750 gr | 22 mm Picatinny Rail | Yes | Matte Black / Glossy Black | Plastic Hardcase |













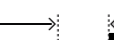

RX1250 BLACK

AIR RIFLE RX1250



RX1250 CAMO

| |  Piston Type |  Muzzle Output Speed* |  Power (Joule) |  Magazine Capacity |  Stock |  Total Length |  Barrel Length |  Type of Barrel |  Twist Rate |  Weight |  Scope Rail |  Replacement Magazine |  Colour Option |  Case |
|------------------|---|--|---|---|---|--|---|--|--|--|--|--|---|--|
| 4.5 mm / .177cal | Gas Piston | 780 FPS | < 20 J | Single | Syntetic/ Camo Max 5 | 1100 mm (43.30) | 450 mm | Rifled | 1:15 | 3050 gr | 11 mm Dovetail | No | Matte Black | Cardboard |
| 5.5 mm / .22 cal | Gas Piston | 650 FPS | < 20 J | Single | Syntetic/ Camo Max 5 | 1100 mm (43.30) | 450 mm | Rifled | 1:15 | 3050 gr | 11 mm Dovetail | No | Matte Black | Cardboard |







aselkon 



www.aselkonarms.com

2 0 2 3



Büyükkayacık O.S.B. 516 Nolu Sk. No:19-19/1

Telephone : +90 332 342 26 12 / +90 332 342 40 04 / Mobile: +90 532 136 08 96

Mobile Export : +90 553 407 00 86

E-Mail : info@aselkon.com.tr / export@aselkon.com.tr

www.aselkonarms.com

Aselkon reserves the right to make modifications to the products shown in this catalogue at any time without prior notice. The finishings, color and patterns shown in this catalogue are approximate, as a printed reproduction causes inevitable color differences. The illustrations and descriptions contained in this catalogue are only provided as an indication.